

Demagnetizers

Choice of demagnetizer:

Shapes, dimensions, steel quality of the components that have to be demagnetized as well as the duty cycle of the demagnetizer contain the necessary information to solve your demagnetizing problems.

Platen Demagnetizers Type DM3 / DM4 / DM5 / EasyLogic

Intended use:

These were developed for toolmakers, workshops of general production mechanics and are usually used for thin pieces.

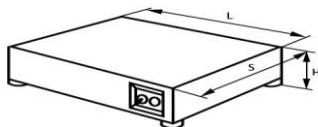

Model	Dimensions (mm)			Voltage	Weight (kg)
	L	S	H		
DM3	250	180	87	230	9
DM4	280	266	87	230	14
DM5	400	306	87	230	19
EasyLogic	280	280	87	230	15

Hand Demagnetizers Type DEM-HD1 / DEM-HD2

Intended use:

These were developed for demagnetization of bulky pieces or pieces that are hard to reach.

Features	HD1	HD2
Active area dimensions	105 x 75 mm	105 x 95 mm
Voltage	220-240V / 50Hz	220-240V / 50Hz
Depth of magnetic field	20mm	40mm
Weight	1.9kg	2.2kg



Tunnel Demagnetizers Type TDM 1 (T1) / TDM 2 (T2) / TDM 4 (T4) / TDM 5 (T5)

Intended use:

These were developed for demagnetization of bulky, thick or high components thanks to their action form the periphery to the very heart of the metal.

Designed for continuous operation cycle

- . Coil encapsulated in a high performance epoxy resin
- . Extremely stable construction
- . During the demagnetization cycle the workpiece should be moved at low and constant speed through the alternative field of demagnetizer (recommended speed: 0.05 to 0.2 m/sec.)

Included with purchase:

- ON/OFF switch, fuses and control leads

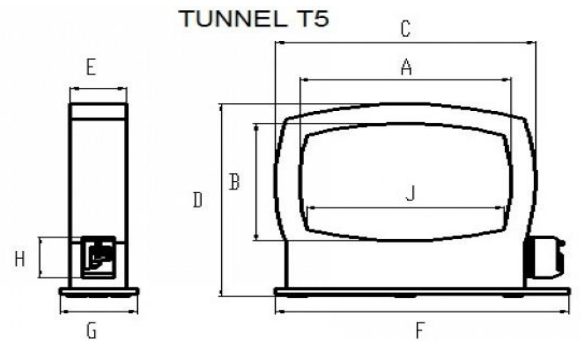

Product	A	B	C	D	E	F	G	H	Weight
T1	180	180	310	432	200	434	230	150	55
T2	255	255	380	488	200	470	230	150	70
T4	460	465	600	731	170	631	230	150	95
T5	600	420	740	676	160	835	220	150	115

Reference	Power High Power 30% duty cycle	Power (VA) Standard continuous duty cycle
DM T1	3200	1840
DM T2	7200	4140
DM T4	14000	8050
DM T5	16800	9660

On request Automatic Tunnel demagnetizers

Intended use:

The components to be demagnetized are fed into the alternating magnetic field by a conveyor belt, driven by a geared motor. This type of equipment can be made to size to suit your application. Contact us for more information.



Magnetic Measurement

We can offer a range of measurement equipment which allows quantifying precisely the level of magnetic induction at a specific location.

Gauss Meter

- Analog display
- Measuring Range: 0-20 Gauss
- Accuracy: 5 Gauss
- Dimensions: D.63 x 33mm
- Weight: 62g



Gauss Meter Digital

- Screen with digital display, strong ABS body
- Measuring range: 0 to 1999 Gauss
- Accuracy: 2% of indicated value or 1 Gauss
- Calibration: 0 Gauss
- Back lighting touch, automatic standby mode
- Dimensions: 76 x 63 x 32 mm
- Weight: 110g

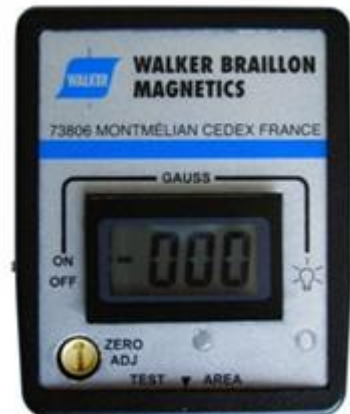

For more information, please contact us on 01525 372714 or by Email: Sales@LHS.uk.com or visit our website
Web: <http://www.LHS.uk.com>